

# SolarChain - DC-to-AC Conversion System

Oleksandr +38(097)377-71-47

# General context of the decision

Global growth of electricity consumption in the world

the world's desire to increase the share of "green" electricity

the war in Ukraine destroyed up to 9 GW of generation

Constant increase in electricity tariffs

increase in the number of electric vehicles

# Industry context of the solution

In 2023-2024, the prices of photovoltaic equipment have decreased by more than 50%, and this trend will continue.

The prices of modern batteries with the latest chemical formulations (LiFePo<sub>4</sub>, LTO, N+ Sodium) will also decrease by more than 50% in 2023-2024, and this trend will continue.

The development of power semiconductor products such as MOSFETs and IGBTs in the automotive industry (electric vehicles) is helping to reduce the cost of high-power integrated circuits.

## General problems

The need for low-power hybrid solutions can be considered solved (up to 50kW)

there is a need for 100-500kw solutions for business/public sector, etc.

Existing solutions have a cost of 350-450 euros per kW, which is quite expensive to distribute

existing solutions usually use a PWM (pulse width modulation) conversion tool with a high percentage of losses

## Problems of hybrid inverters with a capacity of 100-200 kW

the number of specialized (powerful) MPTTs in modern hybrid systems is limited (usually even in solutions of 100 kW no more than 4x), which limits the flexibility of photovoltaic fields (strings)

the need for specialized equipment and narrow-profile specialists

high costs when it is necessary to increase the capacity of batteries

the use of PWM conversion at limit modes (at full load) leads to the generation of a large amount of heat, which leads to the need to use special solutions for cooling the entire system

# SolarChain Solutions: Building Principles

Serial connection of DC sources using electronic switches, which provide the ability to control the connection and disconnection of each source in the electrical circuit.

The total voltage of the system is equal to the sum of the voltages of all DC sources.

The maximum power of the system is limited by the minimum current of any cell in the circuit and the rated current of the electronic keys.

# SolarChain Solution: Structural Diagram

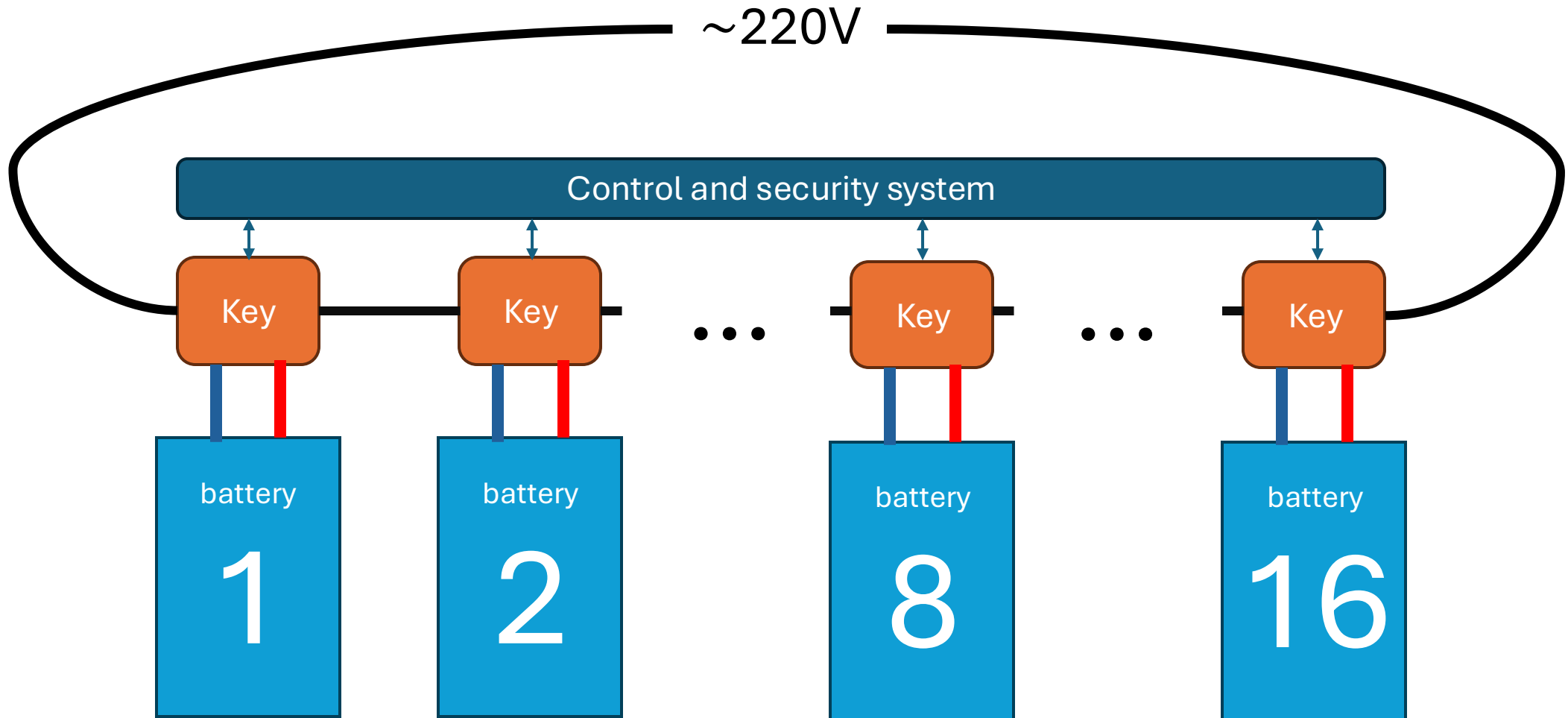

# SolarChain Solution: Opportunities

development of available powerful solutions from 100 to 200 kW based on low-voltage batteries

significant (up to 100%) reduction of losses during AC generation compared to traditional methods (PWM modulation)

monitoring the status of each hot-swappable battery

independence of the system operation from the state of operability, capacity of each battery, in contrast to conventional high-voltage batteries

# SolarChain Solution: Opportunities

develop universal high voltage and power systems that provide alternating current at 50 Hz and 60 Hz, as well as direct current (for fast charging of electric vehicles)

creation of powerful distributed hybrid (autonomous) inverters

charging each of the batteries in the circuit with a separate MPPT tracker (or several), which significantly increases the flexibility of building photovoltaic fields

# SolarChain Solution: Opportunities

flexible adjustment of electrical capacity  
(and/or power) by phase

construction of distributed hybrid (autonomous)  
inverters at existing grid solar stations (including  
large-power ones)

construction of inverters on high-voltage  
batteries with a generation voltage of 10 kV  
(voltage for transportation in distribution power  
grids)

## Application Scenarios: Large Solar Grid Stations

During blackouts, on-grid solar power plants do not generate electricity to the grid, which is a direct loss

If there is an appropriate capacity of batteries, it becomes possible to sell electricity in times of greatest demand (with a price many times more than during the day)

if necessary, provide local power supply during blackout hours

## Application Scenarios: Home Solar Hybrid Stations

---

A significant reduction in the cost of batteries allows even private households to build large-capacity autonomous energy supply systems

---

due to the ability to build such a hybrid inverter distributed and with a large number of MPPT trackers, it is possible to optimize photovoltaic fields with complex roof geometry as much as possible

---

use such a hybrid inverter as a station for fast charging of an electric vehicle (even in the absence of mains power supply)

Application Scenarios:  
100-200kW Electric  
Power Business  
Solution

---

A significant reduction in the cost of batteries makes it possible to build large-capacity hybrid (autonomous) power supply systems for business with flexible parameters

---

increased number of MPPT trackers reduces system charging time

---

the ability to sell residual electrical energy during the day from photovoltaic fields and during "rush hours" from batteries

---

use such a hybrid inverter as a fast charging station for an electric vehicle for business (even in the absence of mains power supply)

# Patent

A patent for a utility model No. 158281 dated 15.01.2025 for the "DC to AC input energy conversion system" was issued, which is the basis of SolarChain technology



# Ways to improve

---

Improving the control system of cell controllers

---

application of a communication system based on industrial CAN protocols using passive fiber optic lines

---

the use of PWM transformations on each circuit (losses when used in such a model are reduced significantly, i.e. the voltage difference decreases in proportion to the number of cells in the circuit

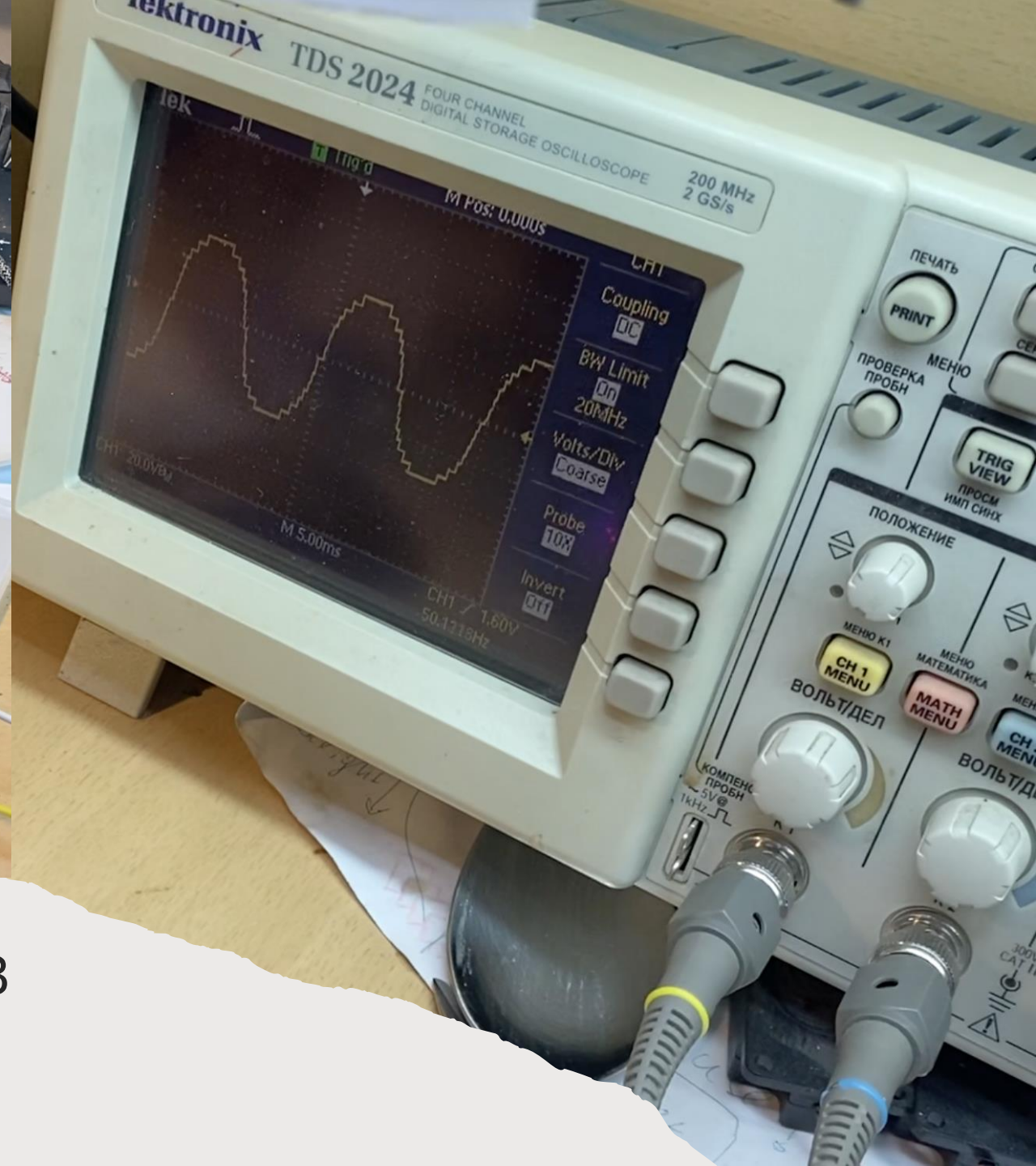
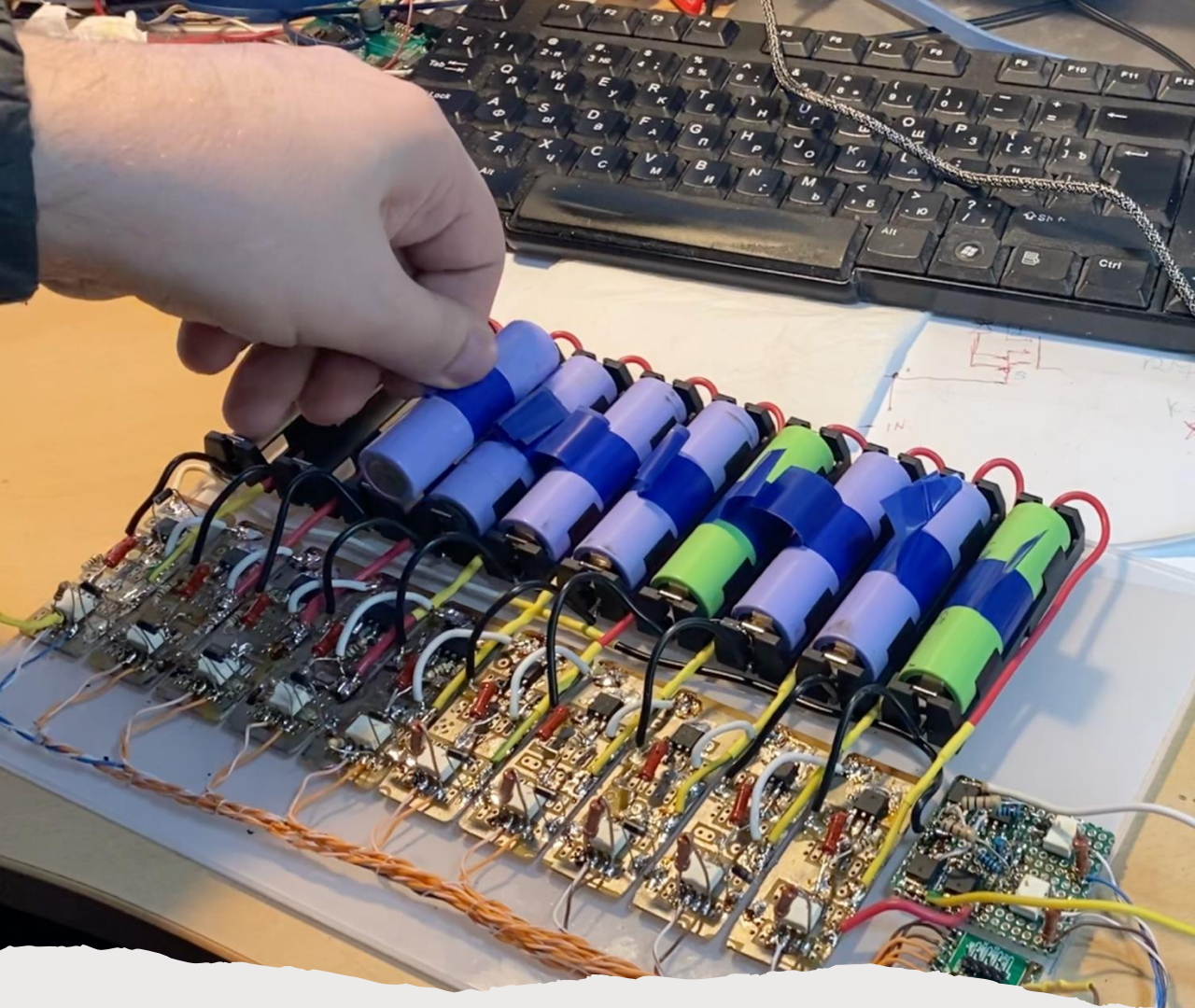

## Milestones: testing an idea. Start 2023

Create a layout to validate the SolarChain schematic diagram

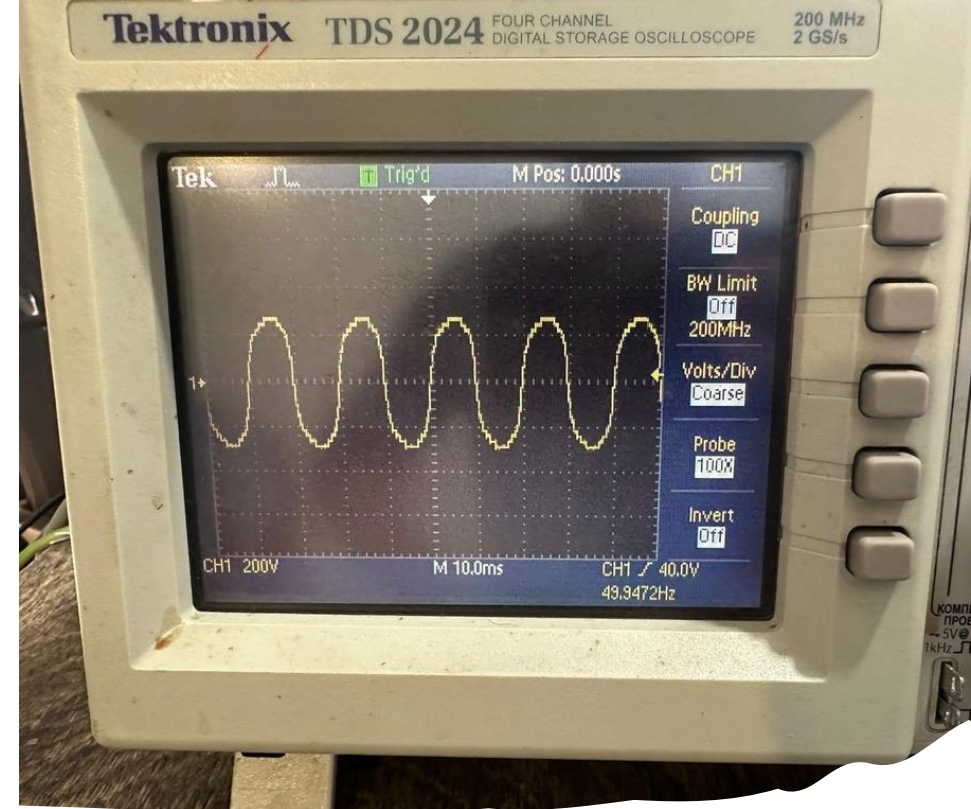

Milestones: solution system  
up to 22kw for the 2023-  
2024 phase

construction of a working system with an  
electrical power of up to 22 kW per phase

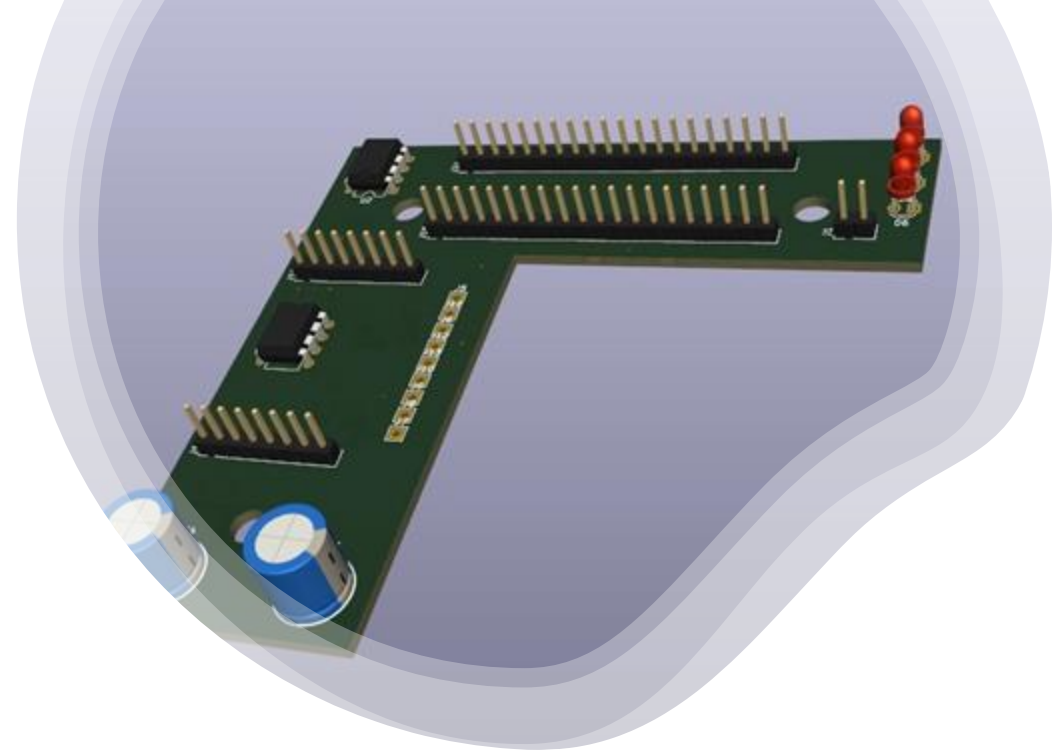
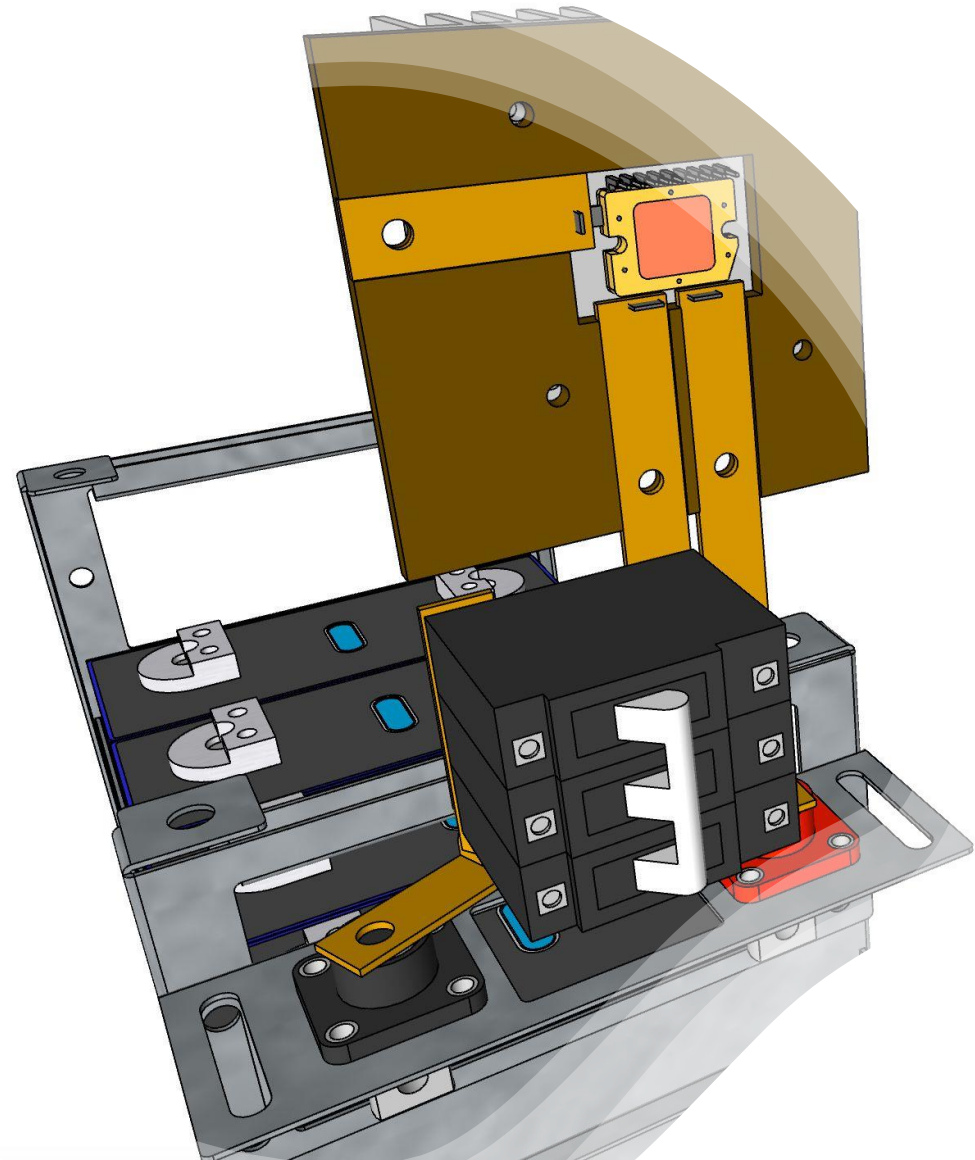

construction of a SolarChain system up to 70 kW per phase with a distributed control system

**Milestones: trial operation up to 200 kW of electrical power. 2024-2025**

# Ways to develop and improve SolarChain

Development of a transformer output stage for high-power systems

development of a CAN control system on passive optical infrastructure

development of a CAN control system based on CANoverPower technology

development of an 11 kV high-voltage inverter